

EZ CLAW® CENTER POST MOUNT PARTS LIST



PART A
BASE PLATE MEMBER
EZ-0241
QUANTITY: 1



PART B
UPRIGHT SUPPORT
EZ-0242
QUANTITY: 1



PART C
CENTER POST
EZ-0243
QUANTITY: 2



PART D
UNIVERSAL HEAD MOUNT
EZ-0244
QUANTITY: 1



PART E
FRAME ANCHOR
EZ-0245
QUANTITY: 4



PART F
BASE SUPPORT MEMBER
EZ-0248
QUANTITY: 1



MOUNTING HARDWARE

(QTY 8) 1/2-13 X 13" LONG G8 BOLT
(QTY 16) 1/2-13 G8 FLAT WASHER-YZN
(QTY 8) 1/2-13 G8 LOCK NUT-YZN

ASSEMBLY HARDWARE

(QTY 36) 3/8-16X1" LONG G8 FL BOLT
(QTY 36) 3/8-16 FL LOCKNUT

Assembly Instructions

- 1) Locate Base Plate Member (Part A) and Center Post (Part C). Set Part C on Part A and install nuts and bolts loosely through the 4 holes in the back and two holes in the bottom. Ensure head of the bolts are oriented as shown (Figure 1) for proper frame rail clearance. After all nuts and bolts are installed tighten all bolts.
- 2) Locate Base Support Member (Part F). Install on assembly from step 1. Loosely install 4 bolts and nuts through the front of Part F and 6 bolts from the bottom as shown. After all bolts are installed proceed with tightening, making sure slotted holes for the frame are aligned.
- 3) Locate Upright Support (Part B) and connect to back side of Part C with 4 nuts and bolts. Do not tighten bolts at this time. Set assembly aside.
- 4) Locate the second Center Post (Part C) and the Universal Head Mount (Part D). Set Part D on top of Part C and install nut and bolts through the 4 holes in the back and 2 holes on top. After all bolts are installed proceed with tightening.
- 5) Set Head Assembly (Step 4) on top of Base Assembly (Step 1-3). Loosely install 4 nuts and bolts through Part Band 2 nuts and bolts in the center to join the uprights. After all nuts and bolts are installed tighten all bolts.
- 6) Stand assembled Center Post Mount in desired location on the frame rails of the truck. Be aware of and move any frame fasteners that may be in the way.
- 7) Locate 1/2" Mounting Bolts and flat washers from the included Mounting Hardware Kit. Install flat washer on 13" bolt and install bolt down through the base of the center post mount avoiding any frame hardware that may exist on the truck. Note: The base of the CPM is universal and will allow for offset holes to be utilized for mounting.
- 8) Locate Frame Anchor (Part E) and 1/2" nuts. Install Part E on two of the bolt assemblies making sure it crosses under the frame. Install 1/2" flat washers and lock nuts. Repeat for the other 3 frame anchors.
- 9) If 1/2" Mounting Bolts do not use the front hole in the Base Support Member (Part F), extra bolts have been provided for these locations.

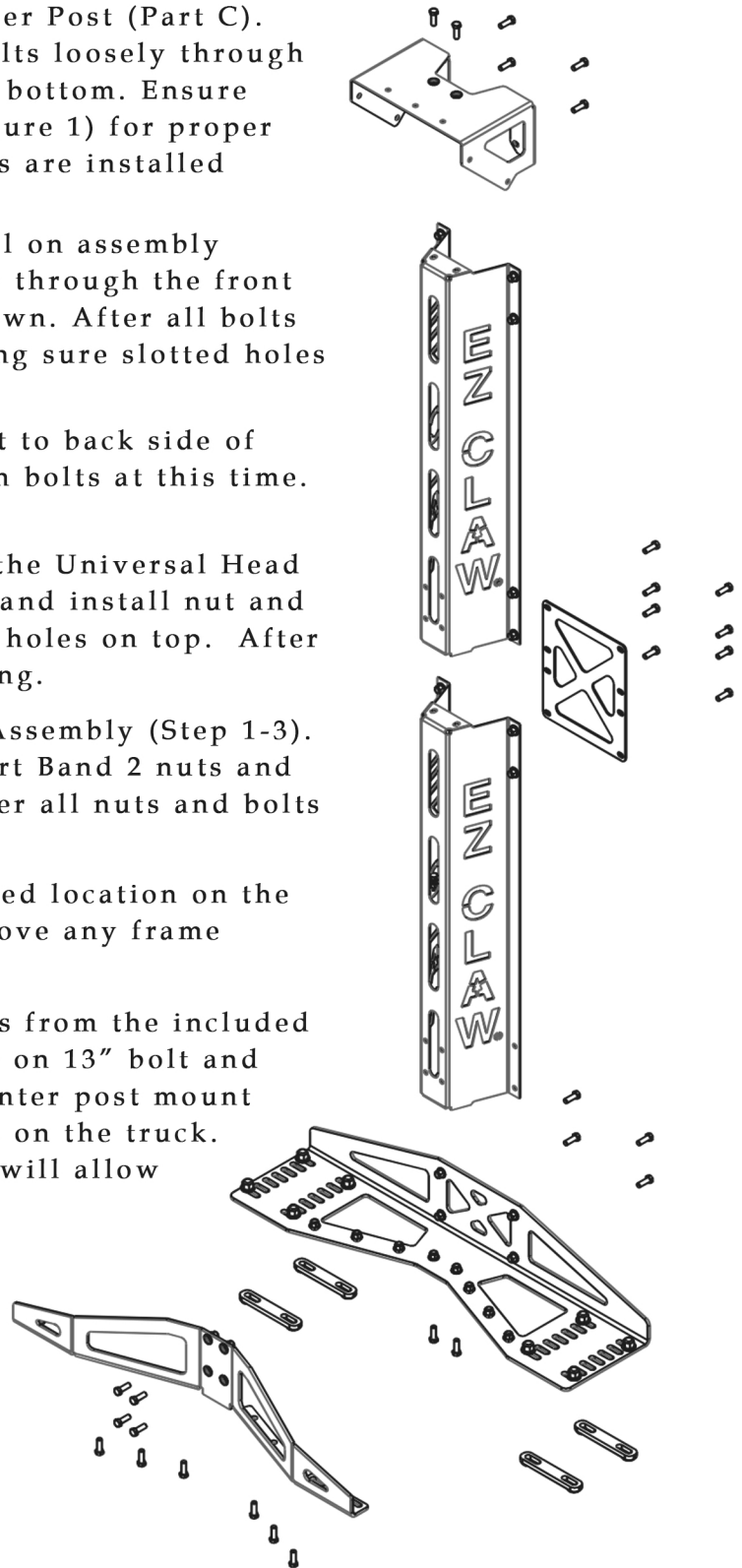

Figure 1

(cont.)

Assembly Instructions cont.

- 10) Locate the EZ Claw Tensioner(s) (sold separately) and install on the universal head mount (see figure 3), utilizing mounting hardware supplied with the tensioner. Ensure the tensioners are mounted so the cable extends from the top, guiding over the stainless steel guide roller as shown.
- 11) Attach brake, electric and hydraulic lines to the EZ Claw tensioners. EZ Claw Sling (Part# EZCS) or EZ Claw Hose and Cable Block (Part# EZCHCH38) are recommended.

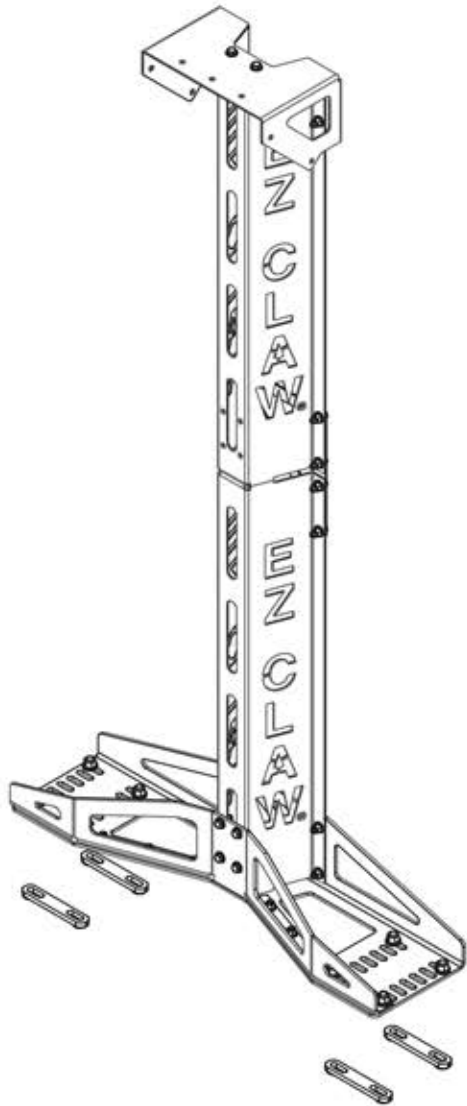

Figure 2
Assembled Center Post Mount

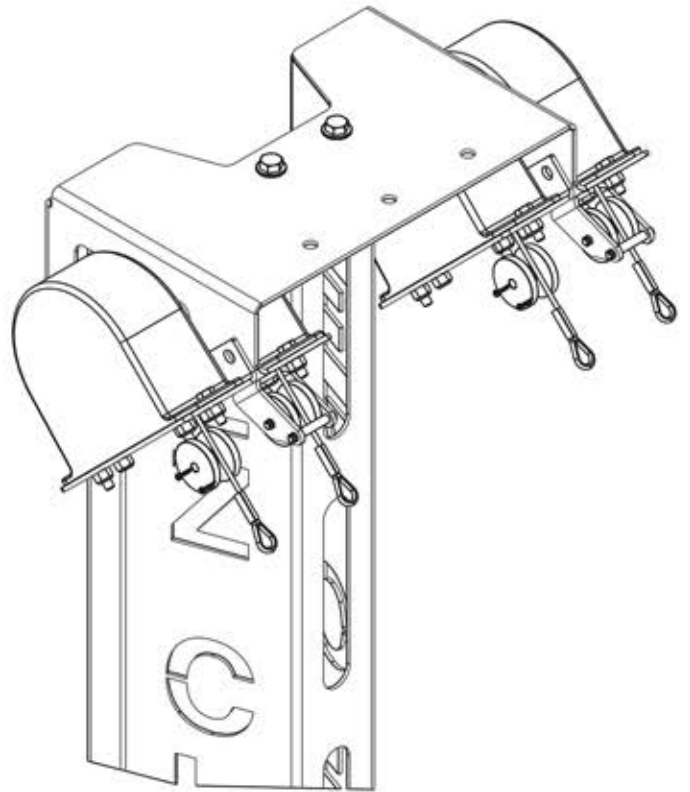

Figure 3
Universal Head Mount with
Tensioners (sold separately)